

Vectorworks Educational Version

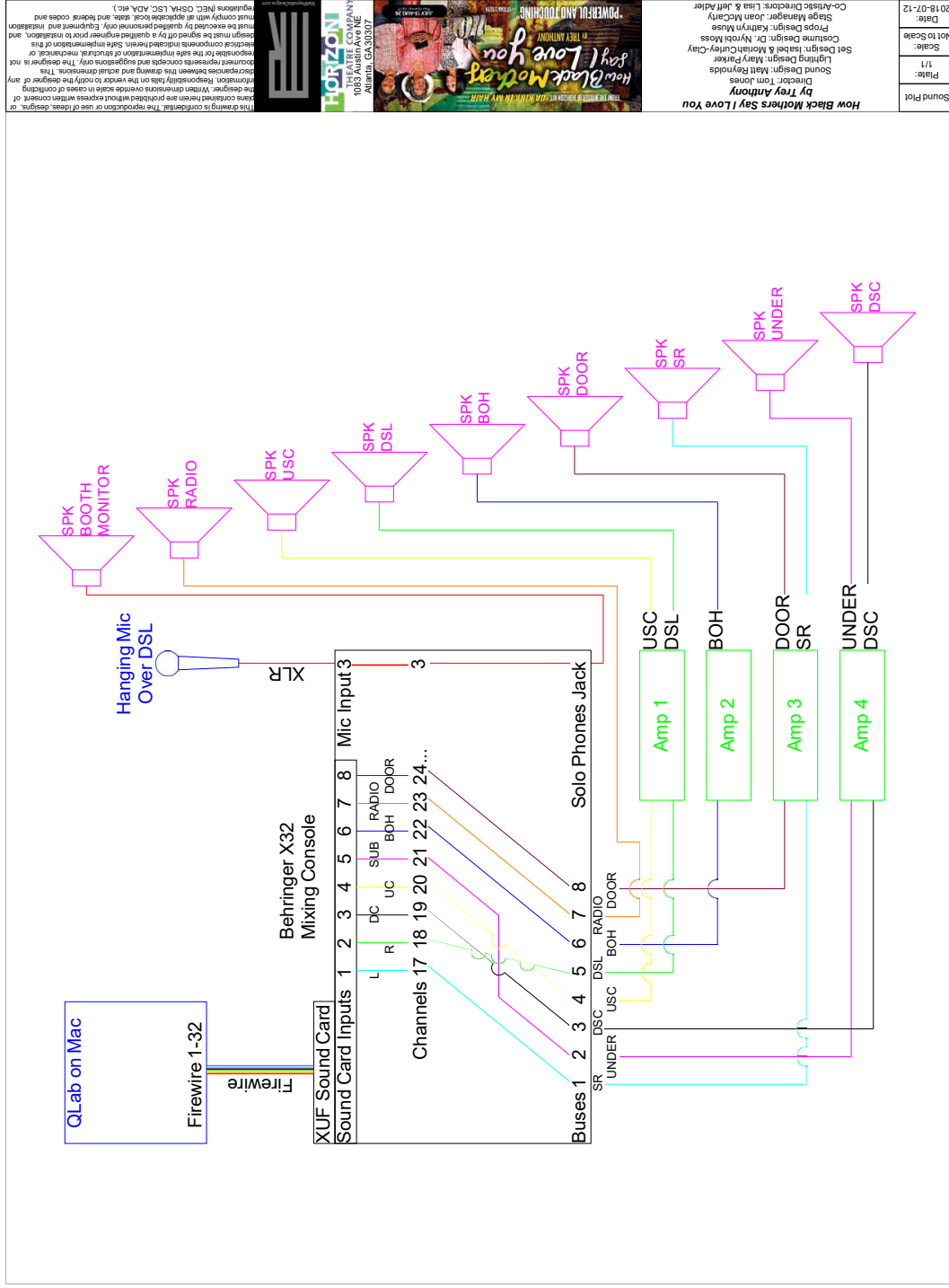

Vectorworks Educational Version

How Black Mothers Say Love You
 By **Troy Anthony**
 Director: Tom Jones
 Sound Design: Matt Reynolds
 Lighting Design: Mary Parer
 Set Design: Sarah & MonahCurry-Clay
 Costume Design: Dr. Nyota Moss
 Props Design: Kathryn Muse
 Stage Manager: Joan McCarty
 Co-Artistic Directors: Lisa & Jeff Adler

Horizon THEATRE COMPANY
 1088 Austin Ave NE
 Atlanta, GA 30307

POWERFUL AND TOUCHING
How Black Mothers Say Love You
 BY TROY ANTHONY
 A PLAY BY TROY ANTHONY

HORIZON THEATRE COMPANY
 1088 Austin Ave NE
 Atlanta, GA 30307

This drawing is confidential. The reproduction or use of these designs, or plans contained herein are prohibited without express written consent of the designer. When dimensions overlap scale in cases of conflicting information, responsibility lies on the works to avoid the designer of any discrepancies between the drawing and actual dimensions. This document represents concepts and suggestions only. The designer is not responsible for the safe implementation of structural, mechanical or electrical components indicated herein. Safe implementation of this design must be supervised by a qualified engineer prior to installation, and must comply with all applicable local, state, and federal codes and regulations (IEC, OSHA, LSC, ADA, etc.)

Sound Plot
 Plate: 1/1
 Scale: Not to Scale
 Date: 2018-07-12



HOW BLACK MOTHERS SAY I LOVE YOU by Trey Anthony	
Sound Cue List	
Director: Tom Jones	Playwright: Trey Anthony
Sound Design: Matt Reynolds	Lighting Design: Mary Parker
Scene Design: Isabel & Moriah Curley-Clay	Costume Design: Nyrobi Moss
Props Design: Kathryn Muse	Stage Manager: Joan McCarty

Date: 7/8/2018

Cue	Page	Scn	GO!	Description	File	Notes
TEST	N/A	N/A	"Testing Sound!"	Test each speaker group	✓	
A	N/A	N/A	House Opens	Preshow music: Mento, calypso, reggae	✓	
B	N/A	N/A	Ready, with house to half	Fade out music for curtain speech	✓	
D	3	1.1	With lights up	Holy Ghost Power	✓	D/Cd: can I stay?
D.5	3	1.1	D sees Cd	Fade to radio	✓	
E	?	1.1	"you cut off all your hair"	Fade out radio	✓	
F	8	1.1	Cd reaches stairs	Awaken	✓	
G	9	1.2	With lights up (laughter)	Quick music out	✓	Cd/V: kids? How's Mom?
H	15	1.2	"than fight and be with us"	Night song	✓	
J	17	1.3	D at top step	Fade to radio and autofollow out	✓	D/Cd/V: bedtime, ignore sexuality
L	21	1.3	"Thanks "	Night song trim1	✓	Cloe consoles
P	22	1.4	With lights up (V enters)	xf to radio	✓	V/Cd: Love, cheating, happiness
Q	33	1.4	"I'll just do the salad "	Say Ladeo trim1 (or Take Your Meat Out Me Rice-trim1)	✓	
R1		1.5	"6 years to sort things out"	Fade in Cloe music in radio	✓	
S	41	1.5	D exits with Val, Cloe teases	Awaken (or similar) underscores. Agitated but not furious.	✓	Awaken-chorus2-agitated
T	41	1.5	"the hell alone"	Dip down music	✓	Cd feels Cloe
U	42	1.5	"you don't believe me, do you "	Swell Awaken for transition	✓	Awaken-addstrings-transition
U3.5	42	1.5	Cloe turns and laughs on pouf	Laugh	✓	Awaken-addstrings-transition
U4	42	1.5	Cloe sits in recliner and laughs	Laugh	✓	
U5	42	1.5	Cloe exits	Stop laugh	✓	
W	46	1.6	"I'll go get my hats "	Transition: Pinks Hats or similar	✓	PinkHat-clean [look for other]





Cue	Page	Scn	GO!	Description	File	Notes
X	47	1.7	D puts hat on CD, moves around loveseat	Dip down music to radio to underscore	✓	Cd/V/D: hats, fight over 6 yrs
Y	47	1.7	"I have the hat for you__"	Swell Pink Hats (or similar) for presentation of THE hat	✓	
Z	48	1.7	" <u>Now</u> that is what you..."	Dip down music to radio to underscore	✓	
AB	48	1.7	"The one Joyce gave her"	Music out	✓	
AC	51	1.7	"Do you want me here or not"; Cloe enters	Brief phrase of When Doves Cry Orch	✓	
AD	52	1.7	"should have left you right there__"	When Doves Cry Orch resumes, settles into black	✓	
AG	N/A	N/A	With house to half	Fade out music; curtain speech?	✓	
AH	N/A	N/A	With lights up	When Doves Cry Orch leads us into black, crossfade to All This Love	✓	
AK	55	2.1	"I hate goodbyes"	Slow fade in Bobby McFerrin "Thinkin About Your Body"	✓	
AM	59	2.1	"She doesn't have to__"	When Doves Cry trim1	✓	
AQ	63	2.2	D goes into audience	Jamaican street sounds	✓	
AR	64	2.2	"Bring her inside__"	Crossfade to Jamaica Farewell (1 verse, autofade out)	✓	
AR5	65	2.2	"Need her now for what"; Cloe and Cd enter	Cloe music	✓	
AS	66	2.2	Cd sits	Last chorus of Jamaica Farewell, autofollow to Shake Senora	✓	
AS8	66	2.2	"I had a dream last night" Cloe appears in audience	Cloe music	✓	
AU	72	2.3	"I will not <u>tolerate</u> "	Phone ring	✓	
AW	72	2.3	"Grab my bible__"	Idris Muhammed or similar ethereal music underscores birth memory	✓	Cut off drum intro
AX	73	2.4	"it's a girl"	Baby cry, then music out	✓	
AY	78	2.5	"She'll like that__"	Take 6's Come Unto Me	✓	[What drives the male a capella choice?]
AV	72	2.3	V picks up phone	Ring out	✓	





Cue	Page	Scn	GO!	Description	File	Notes
AZ	79	2.6	Cd sits and takes bible	Music out	✓	Cd/V/D: reading verse, congrats, a mother wants
BA	83	2.6	"leaves her child, huh?" Cloe enters	Pointer's Wayfaring Stranger underneath dialogue	✓	
BA3	83	2.6	"Left and didn't look back"	Music out	✓	
BA4	84	2.6	D touches chair SR	Cloe music returns	✓	
BB	84	2.7	Cloe stomps (tantrum)	Crossfade to reversed Pointer, Prince outtakes, Awaken-agitated	✓	Tantrum
BB8	84	2.7	Cloe shakes arms/head DC	Prince screams	✓	
BC	84	2.7	Cloe on floor, slams 2x, spins, slams 2x, spins	Cloe sobs, breathes, crossfade back to gentle Pointer	✓	
BD	85	2.8	D puts feet up on couch	Crossfade to Take 6's Come Unto Me trim (or something similarly sweet and forgiving, but maybe tired)	✓	D/Cd: forgiveness
BF	85	2.8	D wakes up	Quick fade out music	✓	
BG	89	2.8	"your God my God"	Hymn resumes gently underneath	✓	
BK	89	2.8	2nd "part me from you"	Hymn resumes, swells into black, AF Curtain Call	✓	
BP	N/A	N/A	Ccall complete, with house lights up	Fade out music (if necessary for post-show speech)	✓	
BQ	N/A	N/A	If wanting music after post-show speech	Jolly Boys	✓	
BR	N/A	N/A	If wanting to fade out post-show music	Fade out music	✓	





HOW BLACK MOTHERS SAY I LOVE YOU by Trey Anthony	
Sound Startup/Shutdown	
Director: Tom Jones	Playwright: Trey Anthony
Sound Design: Matt Reynolds	Lighting Design: Mary Parker
Scene Design: Isabel & Moriah Curley-Clay	Costume Design: Nyrobi Moss
Props Design: Kathryn Muse	Stage Manager: Joan McCarty

Date: 07/07/2018

Startup	
1	Upon arrival to the space, sign in at the callboard. Do not leave the building after signing in without express permission from the SM.
2	At the sound position, turn on the Behringer sound mixing console (the power button is on the back on the right). Turn on the wireless mic box above it. Turn on the monitor (button is on the face, volume control is disabled). Turn on running lights as necessary. Switch on the radio practical speaker (on fridge).
3	Log in to the Horizon Media profile with the password "theatre" and click on Qlab in the dock (looks like a beaker containing purple liquid). Open the most recent HBMSILLY show file.
4	ONCE QLAB IS UP AND READY, then switch on the amp rack (orange switch at top right of the rack on your left).
5	On the mixer, select Chs17-24 (button on the far left) and Bus Sends (button in the middle); both buttons are indicated by tape. Unmute Buses 1-8 (MainL, MainR, DC, UC, Sub, BOH, Radio, Door).
6	Sound System Check. Call out, "Testing Sound," then load the "Test" cue (by clicking on it) and hit go. Everything will come on for a 24 seconds, then to each speaker group in order, then all, then fade out. Go down to the stage to verify that all are working and undistorted. If popping, close QLab, unplug and replug the USB, wait 10s, restart QLab and try again.
7	Check all four headsets to ensure they are working properly.
8	When it's time to open house, start the preshow cue (A).

Shutdown	
1	Once the curtain call cue has played out, mute Buses 1-8.
2	IN THE FOLLOWING ORDER: 1. switch off the amps by pressing the orange switch at the top right of the rack. 2. switch off the mixer and cover it. 3. switch off the wireless box. 4. turn off the monitor. 5. turn off the radio speaker.
3	Back at the sound position, close QLab and log out of the Mac.
5	Turn off any running lights and recoil headset cables.
5	Double-check list and request permission to leave from the SM.
Should you have difficulties, immediately notify the SM and contact Matt Reynolds (770-530-6504) for aid.	











